

XT

4x4 ACCESSORIES



**280W FOLDING
SOLAR PANEL KIT**

+ OWNERS/INSTRUCTION MANUAL



Please ensure that you have read the product manual and instruction in full prior to use. Failure to do so may result in incorrect operation and therefore impact on the products performance.

SAFETY/WARNING

- Before using the XTM folding solar panel kit ensure the instructions have been read and understood.
- The folding solar panel kit is not intended for use by young children or infirm persons. Please keep away from pets.
- The XTM folding solar panel kit is designed to charge most 12 volt battery types including: Flooded (Lead acid), Gel, Sealed/Mat(AGM) and VRSLA batteries.
- Always wear the appropriate Personal Protective Equipment (PPE) when working near batteries. This includes gloves and eye protection.
- Ensure battery is being charged in a well-ventilated area. Explosive gases may escape from the battery during charging. Never charge a battery in a closed off space or in an area without ventilation.
- Never smoke, use an open flame or create sparks near a battery or charger whilst charging as gases may cause explosion. Please keep burning cigarettes, flames or other ignition sources away from the charging battery at all times.
- Do NOT attempt to use the folding solar panel kit if the cables or plugs are damaged. These units do not contain serviceable parts. To avoid a hazard ensure that any damage to the unit, cable or plugs are replaced by a qualified technician.
- Do NOT disassemble the folding solar panel kit. The warranty will be void if this instruction is ignored.
- If battery is still connected in the vehicle, ensure vehicle ignition is switched off before charging the battery.
- Do NOT place the folding solar panel kit on fabric/leather/vinyl seats, on the battery or balanced in the engine bay.
- Never charge a frozen battery, non-rechargeable or dry cell battery. A compatible solar controller is required to charge lithium battery. The included controller is not suitable for lithium battery.
- The XTM folding solar panel kit may have sharp edges-please handle with care.
- Do NOT bend or scratch folding solar panel kit.
- Do NOT walk, sit or place heavy items onto the folding solar panel kit or the kit in the bag.
- Do NOT use a high pressure hose to clean the folding solar panel kit. Use a clean microfiber cloth to clean the folding solar panel kit surfaces.

XTM 30A MPPT SOLAR CHARGE CONTROLLER

- Do NOT disassemble or attempt to repair the controller.
- Power connections must remain tight to avoid excessive heating from a loose connection.
- Only charge 12V batteries that comply with the parameters of the controller.
- Battery connection may be wired to one battery or a bank of batteries.
- Keep in a dry well-ventilated area.

IMPORTANT!

***If load wires are not used it is recommended that these wires are covered.**

(1) Connection of components to the controller MUST be completed in the sequence outlined in the following Wiring diagram, paying particular attention to the "+" and "-" wiring. When disconnecting components, the order is reversed.

(2) After turning the controller on, check that the LED indicator is green (if not green, please refer to section 8. Troubleshooting).

● Load self-test function

Load self-test function - the load will show as on when the controller is switched on.

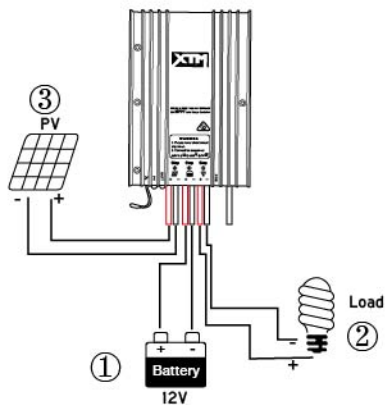

Wiring Diagram

FIRST AID & BATTERIES

- For advice, contact the Poisons Information Centre in Australia (PH:13 1126)
- If battery acid makes contact with the skin or clothing, wash immediately with soap and water.
- If battery acid makes contact with the eyes, hold eyelids apart and flush the eye continuously with fresh running water for at least 15 minutes or until the Poisons information centre advises you to stop.
- If battery acid is swallowed, do not induce vomiting. Drink a glass of water and seek medical assistance.

SPECIFICATION:

SOLAR TECHNOLOGY	High Efficiency Monocrystalline
POWER OUTPUT	280 Watt Max @ 20.5V
TESTING CONDITION	AM1.5, 1000W/m ² , 25°C
OPERATE TEMPERATURE	-40°C to +85°C
ACCESSORIES	5m extension lead with 50A connectors
	90cm extension lead with 50A connector and alligator clips
	30A 12V IP68 Dustproof and waterproof MPPT controller
	Suitable for Deep Cycle, GEL, AGM, VRSLA and Flooded batteries
DIMENSION	705x1060x75mm (Folded)
	1415x1060x35mm (Open)

CAUTION:

- Use and store the product in a dry and well ventilated location.
- Do not use near flammable liquids or explosives.
- Stop use immediately if any wires become loose or electronic components are exposed.

INSTALLATION GUIDE:

Step 1:

Locate a clear sunlit area free from overhanging branches or heavy shade.

Step 2:

Unfold the solar panels, adjust the three supports so the panel sits stable on the ground.

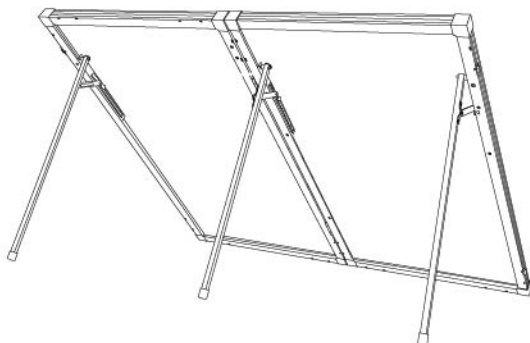

Step 3:

Always face the front side of solar panels toward the sun.

▲ Note:

To ensure maximum possible output, it is recommended that the Solar Panels are regularly moved to follow the sun's movement throughout the day.

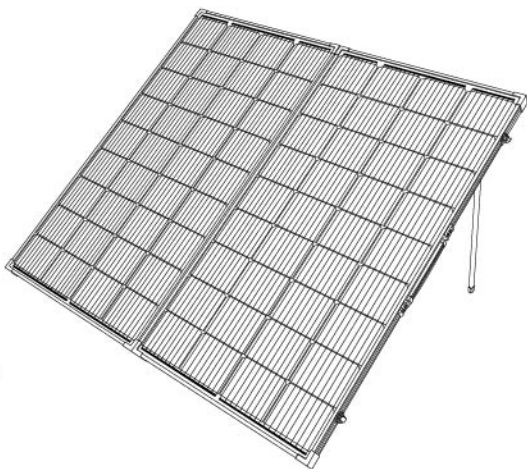

ADJUSTABLE SUPPORT LEGS

- Pull the support leg away from the Solar Panel from the foot of the leg.
The support legs are loose and the angle of the solar panel can be adjusted.
- Position the leg to the desired angle.
Then place the screw in the related notch and then tighten the screw to lock.



CONNECTING YOUR SOLAR PANEL

- Place the panel facing the sun.
Connect the positive and negative clips to your battery.
- Always connect the battery clips to the battery first, before connecting to the solar panel.
The solar controller will then illuminate.

DISCONNECTING YOUR SOLAR PANEL

- Disconnect the solar panel from the controller before removing the battery clips off the battery.

HOW TO CHARGE A 12V BATTERY

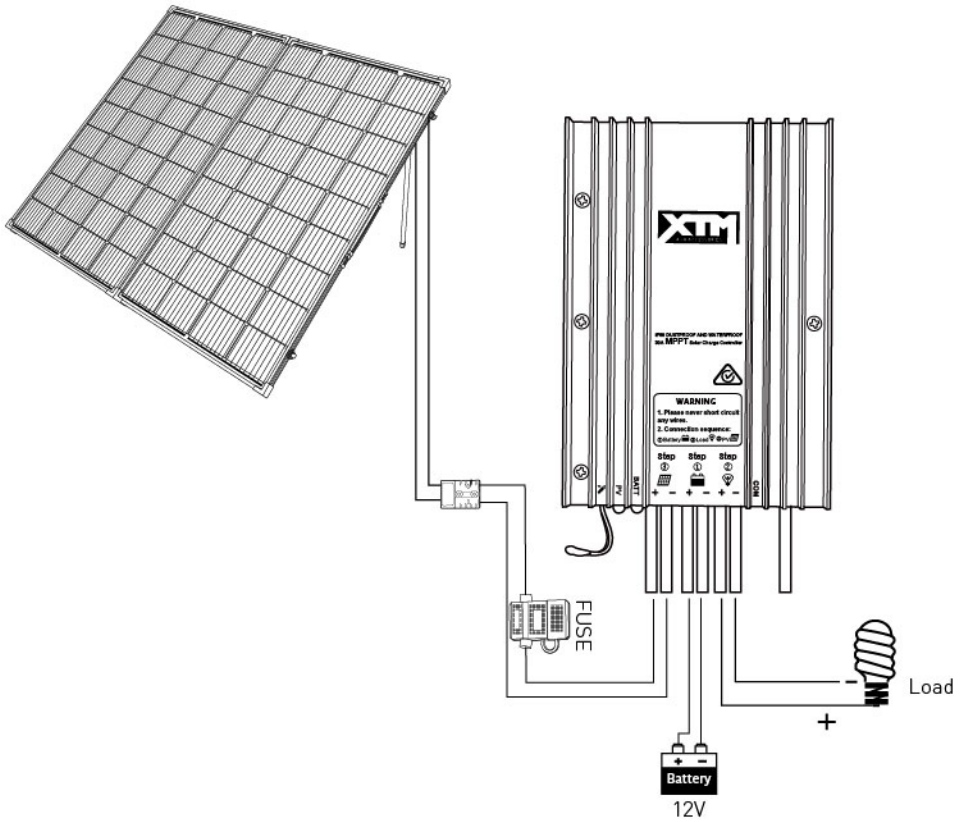

First connect battery to controller.

Second connect load to controller.

Last connect solar panel to controller.

NOTE: Heavy loads should be connected to the battery directly.



XTM 30A MPPT SOLAR CHARGE CONTROLLER

1. SAFETY INFORMATION

- Read all of the instructions in the manual before installation.
- DO NOT disassemble or attempt to repair the controller.
- Do not disconnect the solar module before installing or moving the controller.
- Power connections must remain tight to avoid excessive heating from a loose connection.
- Only charge batteries that comply with the parameters of controller.
- Battery connection may be wired to one battery or a bank of batteries.
- Risk of electric shock due to the high voltages produced, from the photovoltaic (PV) and load when controller is in use.

2. OVERVIEW

The XTM 30A MPPT Solar Charge Controller adapts to the Maximum Power Point Tracking (MPPT) charging method. This enables the systems charging and discharging management to obtain the most radical optimisation, increases system flexibility and reduces overall system running cost. This controller supports a variety of battery types, including sealed, gel & flooded batteries. It can also be used around the home in many applications, such as home solar systems, solar lighting & garden lamps.

Features:

- Advanced Maximum Power Point Tracking (MPPT) technology
- Long lifespan design, made from high quality components within an aluminium housing
- Ultra-fast tracking speed & efficiency
- Accurately recognises & tracks multiple power points
- Photovoltaic (PV) power limitation function

3. PRODUCT SPECIFICATIONS



①	Charging Status LED indicator	④	Battery Positive and Negative Wires
②	Battery Status LED indicator	⑤	Load Positive and Negative Wires
③	PV Positive and Negative Wires	⑥	Waterproof cap

NOTE: 1. The waterproof cap must be fitted to prevent water & dust entering the unit.
2. COM adapter not available with this unit

4. WIRING

IMPORTANT!

***If load wires are not used it is recommended that these wires are covered.**

(1) Connection of components to the controller **MUST** be completed in the sequence outlined in the following Wiring diagram, paying particular attention to the "+" and "-" wiring. When disconnecting components, the order is reversed.

(2) After turning the controller on, check that the LED indicator is green (if not green, please refer to section 8. Troubleshooting).

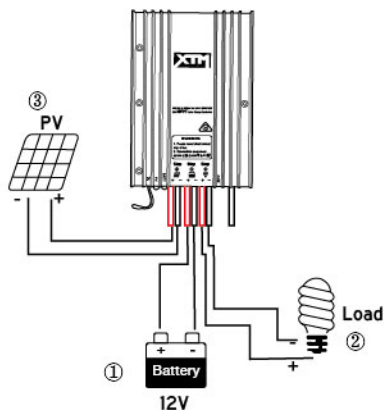

● Load self-test function

Load self-test function - the load will show as on when the controller is switched on.



Wiring Diagram

5. LED INDICATORS

Indicator	Color	Status	Instruction
	Green	On Solid	Photovoltaic (PV) connection normal but low voltage (irradiance) from PV, no charging
	Green	Off	No PV voltage (night time) or PV connection problem
	Green	Slowly Flashing (1 flash per second)	Charging
	Green	Fast Flashing (4 flashes per second)	PV Over voltage
	Green	On Solid	Normal
	Green	Slowly Flashing (1 flash per second)	Full
	Green	Fast Flashing (4 flashes per second)	Over voltage
	Orange	On Solid	Under voltage
	Red	On Solid	Over discharged
	Red	Fast Flashing (4 flashes per second)	Battery Overheating
Charging (green) and battery indicator (orange) flashing simultaneously			System voltage error

6. LOAD WORKING MODE

Note: The controller's 'ON' status indicator, is defaulted to show Load.

7. INBUILT CONTROLLER PROTECTIONS

Photovoltaic (PV) Protections:

● PV Over Current

Where PV over current occurs, battery charging will be limited to the maximum battery current rating. Oversized solar arrays will therefore not operate at peak power.

● PV Short Circuit

Where PV short circuit occurs, or PV input short circuits on low power, charging will stop, the controller will turn off and the led will not be illuminated. Disconnect PV input from controller and check for short circuit in the wiring and reconnect.

WARNING: Damage to the controller may occur where PV input short circuits on high power.

● PV Reverse Polarity

Where reverse polarity occurs, check the wire connections and resume normal operation.

WARNING: If this controller is connected to a different PV to the one supplied and the power from that solar panel (PV) is greater than 585W/12V(1170W/24V) damage WILL occur to controller.

Battery Protections:

● Reverse Polarity

Where battery reverse polarity occurs, check wire connections and resume normal operation.

● Over Voltage (16V)

Where over voltage is detected, the controller will stop charging the battery, to prevent damage to the battery. Refer to section 9 Technical specifications.

● Over Discharge (11.1V)

Where over discharge (low voltage) is detected, the controller will stop power supply to load, to prevent damage to the battery. Refer to section 9 Technical specifications.

● Overheating

The controller monitors environmental temperature via a sensor. Where environmental temperatures exceed 65°C, the controller will cease charging until the temperature reaches 55°C, after which charging will resume.

● Temperature Sensor Error

If temperature sensor faults, the controller will continue to charge/discharge battery at the default temperature of 25°C, to prevent damage to the battery from overcharging & low voltage.

● Load Overload

The controller will disconnect the load where the load current exceeds the maximum load current rating of 1.05 times (31.5 amps). Where overload does occur, reduce load demand and restart controller.

● Load Short Circuit

The controller will disconnect the load if short circuit (greater than or equal to 120 amps) occurs and will attempt reconnection 5 times. If reconnection attempts fail, the user must clear short circuit by disconnecting the controller from the circuit, check all the wiring for the short circuit and reconnect the controller (follow the steps outlined on the front of the controller) to reset. If restart fails, please refer to 8. Troubleshooting.

8. TROUBLESHOOTING

Faults	Possible reasons	Action
LED charging indicator turns off in daylight, despite PV modules under direct sun.	Photovoltaic(PV) array disconnection	Check PV & battery wire connections are correct and tight.
No LED indicator	Battery voltage may be less than 8.5V	Measure battery voltage with a multi-meter. A minimum of 8.5V are required to power the controller.
Battery LED indicator - fast flashing - green	Battery over voltage	Check if battery voltage is higher than the over voltage disconnect and disconnect the PV

Faults	Possible reasons	Action
Battery LED indicator red	Battery over discharged	When the battery voltage is restored to or above LVR point (low voltage reconnect voltage), the load will recover
Battery LED indicator red flashing	Battery Overheating	The controller will automatically turn off until temperature falls below 55 °C, then resume normal operation.
Load output has stopped	Load Overload ^	① Reduce output load demand ② Restart controller.
	Load Short Circuit ^	① Check load connections, clear controller fault. ② Restart controller.

^ Where overload or short circuit occurs and the controller ceases charging, it will then attempt auto-recovery 5 times, in the following timing intervals: 5s, 10s, 15s, 20s and 25s.

9. TECHNICAL SPECIFICATIONS

Item	Model	Tracer7810BP
Nominal system voltage		12/24VDC Auto
Rated charge/discharge current		30A
Rated charge power		390W/12V; 780W/24V
Lead acid	Over Voltage Disconnect Voltage	Sealed/Gel/Flooded: 16V
	Low Voltage Reconnect Voltage	Sealed/Gel/Flooded: 12.6V
	Low Voltage Disconnect Voltage	Sealed/Gel/Flooded: 11.1V
Enclosure		IP68
Mounting hole size		Φ 3.5mm

10. DISCLAIMER

Under the following conditions, product warranty does not cover/apply:

- Damage caused through misuse, including use within unsuitable environments.
- Damage caused as a result of PV, load current, voltage or power exceeding the rated value of the controller.
- Damage caused from use in excessively hot environments.
- If the controller has been disassembled, opened or altered by the user
- Damage caused from natural elements, for example lightning.
- Damage caused during transportation by the user.

FREQUENTLY ASKED QUESTIONS

Q. What type of batteries can be used with the solar battery charger kit?

A. Deep Cycle, Gel, AGM, VRSLA and Flooded batteries. Compatible solar controller is required to charge lithium battery. The included controller is not suitable for lithium battery.

Q. Will the folding solar panel over charge my battery?

A. No. The Solar battery charger kit controller ensures that a steady charge is supplied to the battery without over charging.

Q. Can I extend/lengthen the battery lead wire?

A. If the lead is extended, this can result in a loss of voltage causing insufficient power being transferred from the Solar Panels to the battery. Product modifications will void your warranty.

Q. How do I clean the solar battery charger kit panels?

A. Dust & dirt should first be swept off the panel surface using a soft brush or a microfiber cloth then using a microfiber to wipe the panel surface to remove remaining dirt & grime. It is recommended that any bird droppings be removed as soon as possible to avoid surface damage.

Q. Is the 280W Folding Solar Panel Kit water resistant or waterproof?

A. Yes, the solar panel is water resistant to a rating of IP65.

Q. Is the 12V 30A MPPT Solar Charge Controller waterproof?

A. Yes, the controller is IP68 rated, waterproof and dust proof.

Q. Can the solar charge folding solar panel kit be left on the battery permanently?

A: It is recommended that solar charge folding solar panel kit is checked regularly as leaving a battery on charge permanently may cause damage to your battery.

Q. What is photovoltaic?

A. The photovoltaic(PV) effect are solar cells that produce direct current electricity from sunlight which can be used to power equipment or to recharge a battery.

WARRANTY

Our product is guaranteed to be free from quality and manufacturing defects for a period of 12 months.

If your product becomes defective during this period, SRGS PTY LTD will offer you either a replacement, credit or refund where a product is faulty; wrongly described; different from the sample shown to you or do not do what they are supposed to do.

This warranty will not cover substantially modified product; misuse or abuse of the product contrary to user instructions or packaging label; change of mind and normal wear and tear.

Our goods come with guarantees that cannot be excluded under the Australian Consumer Law. You are entitled to a replacement or refund for a major failure and for compensation for any other reasonably foreseeable loss or damage. You are also entitled to have the goods repaired or replaced if the goods fail to be of acceptable quality and failure does not amount to a major failure.

To claim the warranty, take the product to the front Service Desk of your nearest store of purchase. You will need to show receipt or other proof of purchase. Additional information may be required to process your claim. Should you not be able to provide proof of purchase with a receipt or bank statement, identification showing name, address and signature may be required to process your claim.

Any expenses relating to the return of your product to the store will normally have to be paid by you. For online store purchases, SRGS PTY LTD will pay for the return freight for any product assessed as having a major failure.

The benefits to the customer given by this warranty are in addition to other rights and remedies of the Australian Consumer Law in relation to the goods or services to which this warranty relates.

This warranty is provided by SRGS PTY LTD, 6 Coulthards Avenue, Strathpine QLD 4500, Australia. Phone: 1300 880 764.



PLU	628705
Construction	Monocrystalline solar panels
Max power (Nom.)	280W
Dimensions (folded)	705x1060x75mm
Dimensions (open)	1415x1060x35mm
Max power voltage	20.5V
Max power current	13.66A
Open circuit voltage	24.19V
Short circuit current	15A
Power tolerance	±3%
Cable length	5+0.9 Metre
Operating temperature	-40°C to +85°C
Standard test conditions	AM1.5 1000W/m ² 25°C
Manufactured in	China

PLU: 628705 CODE: 280WSOLARFOLDING

Manufactured & packaged for
SRGS PTY LTD

ABN 23 113 230 050

6 Coulthards Avenue

Strathpine QLD 4500. Australia

MADE IN CHINA



Recyclable Paper